



Handling System for Rack Type Tray Lowerator for Conveyor - H=800/900mm

ITEM # _____

MODEL # _____

NAME # _____

SIS # _____

AIA # _____



865135 (HSTL800)

Tray lowerator for conveyor,
H=800/900mm

Short Form Specification

Item No. _____

Constructed in 304 AISI stainless steel. One lower platform shelf and one upper lowerator shelf. The automatic lifting system for the upper shelf can easily be adjusted for different weights of items by means of adding or removing springs. The easy accessible springs are located behind the interior front plate. Four heavy duty swivelling castors 125mm, 2 with brake. Durable no-mark tread on the castors. Suitable to be used at the end of a tray conveyor to collect empty trays from the drive unit with tray unloader. Lowerator shelf size 538x385mm. Discharge height: 800-900mm. Supplied with one set of 4 corner bumpers.

Main Features

- Automatic lifting system for upper shelf sustains different weights of items by means of adding or removing springs, that is located behind the interior front plate.

Construction

- AISI 304 stainless steel with smooth, easy to clean surfaces.
- Durable no-mark tread on the wheels.

APPROVAL: _____



Experience the Excellence
www.electroluxprofessional.com
professional@electrolux.com

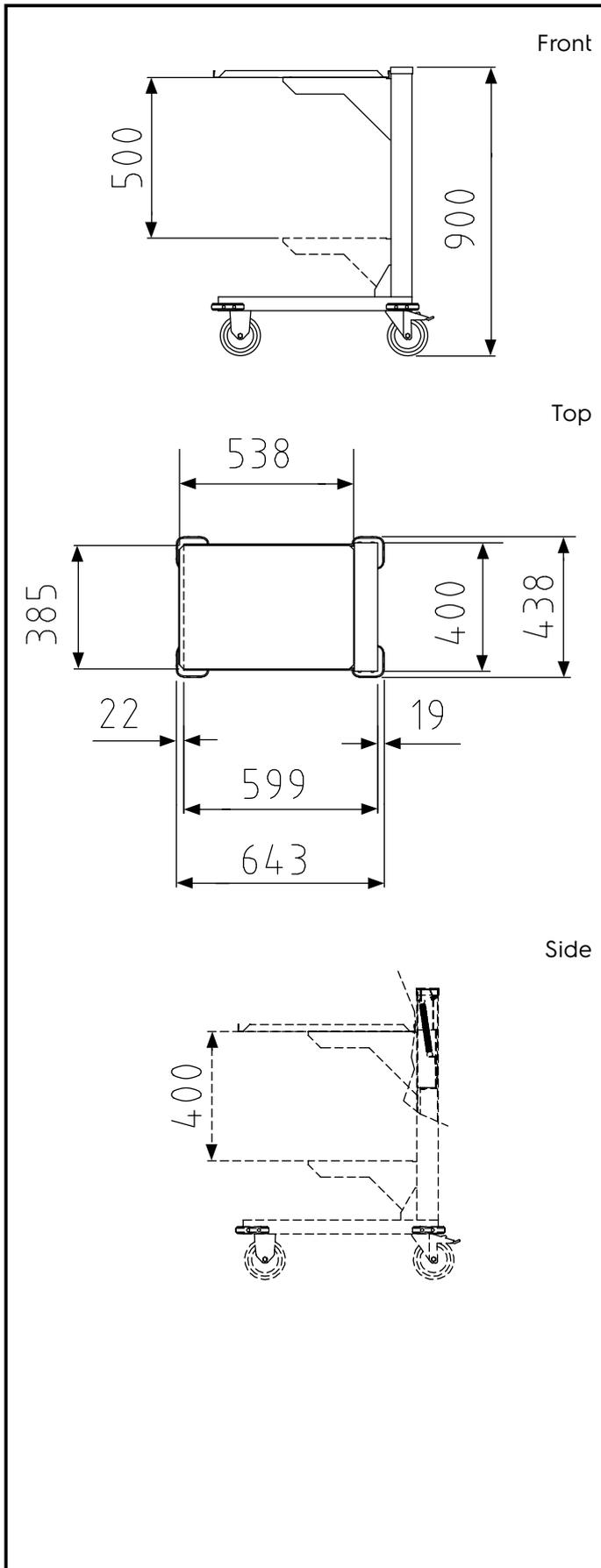

Key Information:

External dimensions, Width:	
865135 (HSTL800)	438 mm
External dimensions, Depth:	643 mm
External dimensions, Height:	900 mm
Net weight:	27 kg